

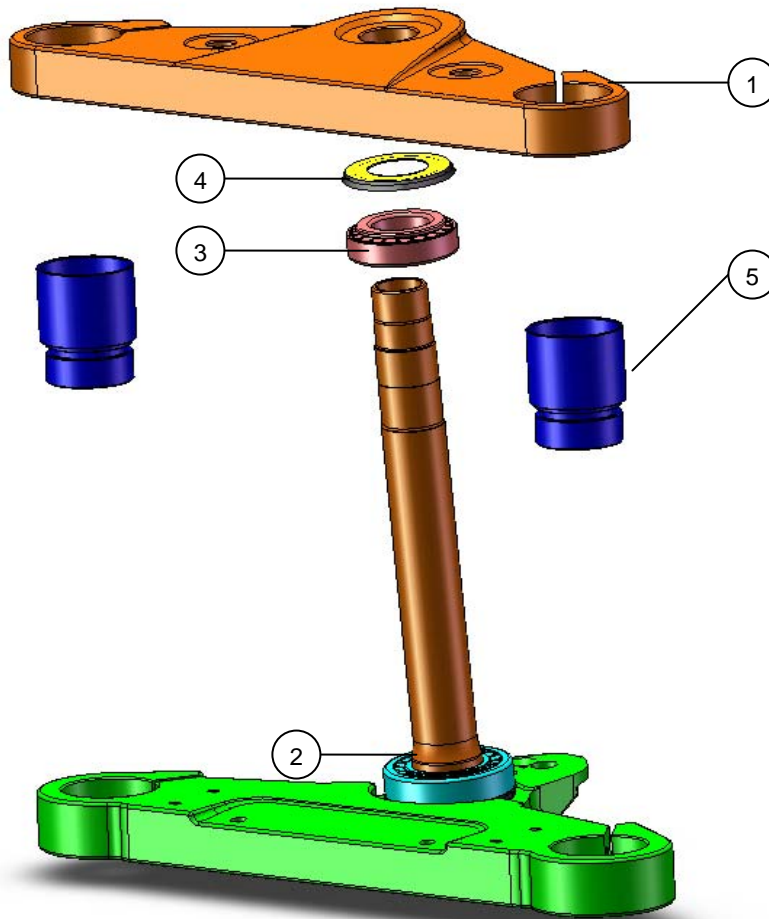

Champion Sidecars EZ-Steer Installation Guide

For
Honda VTX 1300 Motorcycles
Revision 4



#	Part No.	Description (Qty)	#	Part No.	Description (Qty)
	A-EZS-L00-002	Complete kit., VTX 1300	4	BE-E00-008	Seal, bearing, swing arm, HON, stem, top (1)
1	EZ-L00-001	Clamp, Upper,VT3 (1)	5	EZ-H01-010	Extension, fork, assembly, EZ5 (2)
2	EZ-L01-001	Clamp, lower, assembly,VT3 (1)	6	EZ-H01-015	Grease,1oz. bag, assembly, EPZ (1) (not illustrated)
3	BE-H10-001	Bearing, stem, top, small, EZ5/EZ8 (1)	7	EZ-L00-010	Guide, cover, VT3

Champion Motorcycle Accessories Int. Inc
Db a Champion Sidecars 11841 Monarch Street, Garden Grove, Ca. 92841
 (800) 875-0949 (800) 847-0949 Fax (714) 847-1539
www.championtrikes.com

Honda VTX 1300 EZ-Steer Installation Instruction

Installation of the Champion EZ-Steer system is similar to the installation of the OEM triple clamps of your Honda VTX 1300 Motorcycle. We strongly recommend that you use your OEM service manual and follow the prescribed disassembly, installation and torque specifications (except where noted below) for the upper and lower clamp assembly.

Recommended Procedures

- Disconnect all wiring to headlight and remove headlight, windscreen (if so equipped) and brackets from motorcycle.
- Remove handle bars from top clamp.
- Remove brake caliper and brackets; disconnect all mounting points on brake lines. Secure calipers to frame being careful not to damage brake lines.
- The wheel and fork tube assembly can be removed as one complete unit.
- Remove caps and install supplied extensions to fork tubes using the supplied o-rings. Apply lubricant to o-rings and extensions prior to installing to fork tubes. Reinstall OEM caps and o-rings.
- Remove steering lock from OEM bottom clamp and install on Champion's bottom clamp.
- Replacing the upper OEM bearing and race with the Champion supplied bearing and race, install Champion's lower triple clamp to motorcycle reusing original hardware as removed. Torque bearing lock nut to 35 lb. ft.
- Install fork tube covers to bottom clamp if supplied with OEM motorcycle.
- Remove OEM nylon tube cover sliders from lower fork legs and replace with supplied sliders, if required for lower chrome covers on C models. See figure on the right.
- Install Champion upper clamp with OEM washer and dome nut. Leave loose.
- Slide forks up and into the upper clamp until top of extension is flush with top surface of clamp.
- Torque dome nut to 75 lb. ft.
- Ensure that fork tube extensions are flush with top of upper clamp. Torque upper 8mm bolts to 20 lb. ft and lower 10 mm clamp bolts to 30 lb. ft.
- Install handle bars to upper clamp using OEM nut and flat washers.
- Reinstall brake line holders to the lower triple clamp.
- Reinstall all other OEM parts as removed.
- Bleed brakes.
- OEM windshield # 08R80-MEM-100 and light bar # 08V31-MEM-100 can be used on this kit.

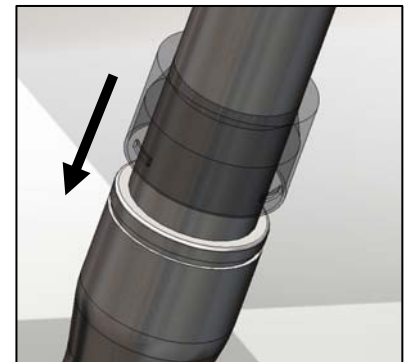

Supplied cover slider

WARNING: If the Champion EZ-Steer system is installed on a motorcycle / sidecar combination and the sidecar is removed, the motorcycle is **not safe** to ride, and OEM triple clamps should be reinstalled to motorcycle.