



RAIDER



2004 to 2013 XL MODELS

*Will not fit XR1200 models

*Nightster, Forty-Eight and Iron 883 models may require additional modifications

****Installation should be installed by a qualified mechanic**

INSTALLATION INSTRUCTIONS

Revision 1

Table of Contents

1.	General Information.....	2
1.1	Installation Information.....	2
1.2	For Your Safety.....	2
1.3	Important Safety Precautions	2
1.4	Specifications.....	3
2.	Removal of Original Parts	4
3.	Installation of Trike Conversion Kit.....	5
3.1	Install New Supplied Belt onto Front Counter Sprocket from Box 2.....	5
3.2	Install OEM Swing Arm Pivot Bearings with C-Clips into Champion Swing Arm from Box 3.....	5
3.3	Installing Champion Swing Arm to Vehicle	5
3.4	Install Shocks.....	5
3.5	Install Rear Brake Lines and Components from Box 2	5
3.6	Assemble Rear End.....	6
3.7	Install Rear Axle Clamps	6
3.8	Install Rear End Assembly.....	6
3.9	Aligning and Tensioning Drive Belt.....	7
3.10	Connect Brake Lines to T-Block	8
3.11	Master Cylinder Installation	8
3.12	Install Body	8
3.13	Install Wheels and Tires	10
4.	Accessories	10
4.1	Grab Handle Installation	10

	Box Contents
Box 1	Tire/Wheel, 2 Shocks
Box 2	Tire/Wheel, Hardware Kit
Box 3	Swing Arm
Box 4	Rear Differential with Pulley (Left)
Box 5	Rear Differential Assembly (Right), Body

1. General Information

The Champion Sidecars Trike Conversion Kit is designed with the utmost consideration for safety, quality and ease of installation. The kit comes complete with all necessary hardware and fasteners. However, it is assumed that the installer has advanced/professional skills in motorcycle servicing. It is recommended that installer obtain an OEM service manual for the vehicle on which the Trike kit is to be installed. Please note with the Nightster model you will need to relocate the license plate. We recommend using a layback license plate mount, for example Champion part # AC-F00-200. In addition you will need to illuminate your license plate. An example of this is a license plate frame with light, Champion part # AC-F00-201.

1.1 Installation Information

The information contained in this Installation Guide is intended for use by technicians of advanced to professional skill levels. Attempting installation without the proper training, tools and equipment could cause injury to you or others. It could also damage the vehicle or cause an unsafe condition.

1.2 For Your Safety

Because this guide is intended for technicians of advanced to professional skill levels, we do not provide warnings about many basic shop safety practices. If you have not received shop safety training or do not feel confident about your knowledge of safety practices, we recommend that you do not attempt to perform the procedures described in this guide.

Some of the most important general safety precautions are given below. Champion Sidecars cannot warn you of every conceivable hazard that can arise. Only you can decide whether or not you should perform a given task.

1.3 Important Safety Precautions

- a. Make sure you have a clear understanding of all basic shop safety practices and that you wear appropriate clothing and use safety equipment. Be especially careful of the following:
 - Read all directions before you begin, and make sure you have the tools, the parts and the skills required to perform the tasks safely and completely.
 - Protect your eyes by using proper safety glasses, goggles or face shields anytime you hammer, drill, grind, pry or work around pressurized air or liquids, and springs or other stored-energy components.
 - Use other protective wear when necessary, for example gloves or safety shoes. Handling hot or sharp parts can cause severe burns or cuts.
 - Protect yourself and others when you have a vehicle up in the air. Anytime you lift a vehicle, either by hoist or a jack, make sure that it is securely supported.
- b. Make sure the engine is turned off before you begin work.
 - Carbon Monoxide poisoning from exhaust gases: be sure there is adequate ventilation whenever you run the engine.
 - Burns from hot parts: Let the engine and exhaust system cool before working on those areas.
 - Injury from moving parts: If running the engine, keep hands, fingers and clothing away from moving/rotating parts.
- c. Gasoline vapor and hydrogen gases from batteries are explosive. To reduce the possibility of fire or explosion, be careful when working near gasoline and batteries.

- d. Use only nonflammable solvent, not gasoline, to clean parts.
- e. Never drain or store gasoline in an open container.
- f. Keep all cigarettes, sparks or flame away from the battery and all fuel related parts.

1.4 Specifications

Overall Length:	91"
Overall Width:	55"
Wheel Base:	64"
Load Capacity:	400 Lb
Tire Size (15"):	205 / 70 / R15
Wheel Size (15" 4 lug)	Offset +35 mm 15x7JJ 4 x 4.5
Tire Pressure:	20-25 PSI
Suspension:	"Zero-Flex" Swing Arm Utilizing Champion Coil-Over Shock
Rear Differential:	Custom built rear differential utilizing OEM V-Rod belt
Brakes:	Original front plus 2 high performance disc brakes in rear

2. Removal of Original Parts

Secure and raise motorcycle 9 to 10 inches using a quality motorcycle lift.

Remove the following from the vehicle. See OEM manual for detailed instructions. Items to be retained for re-installation after modification are noted.

- Left and right saddle bags (if so equipped)
- Left and right rear crash bars, saddlebag rails (if so equipped)
- Disconnect rear brake line at caliper and remove clamp from swing arm (Note: Prior to disconnecting line, depress foot brake and secure in down position (e.g., zip-tie to floor board). This will prevent fluid flow when rear brake line is disconnected. Cap line to prevent introduction of dust/debris into line. Rear brake line and clamp with screw will be used later.)
- Disconnect the wires from the rear brake pressure switch
- Rear brake line at the master cylinder and remove completely from the motorcycle
- Loosen belt tension
- Upper shock bolts
- Swing arm assembly, a.k.a. "Rear Fork" (Note: Pivot bolts to be used later. You may use the OEM spherical bearing and c-clips but it is recommended to use new spherical bearings and c-clips with Champion swing arm.) Figure 1 and 2
- Front sprocket cover (Note: Some exhaust components may need to be loosened or removed for belt removal.)



Figure 1

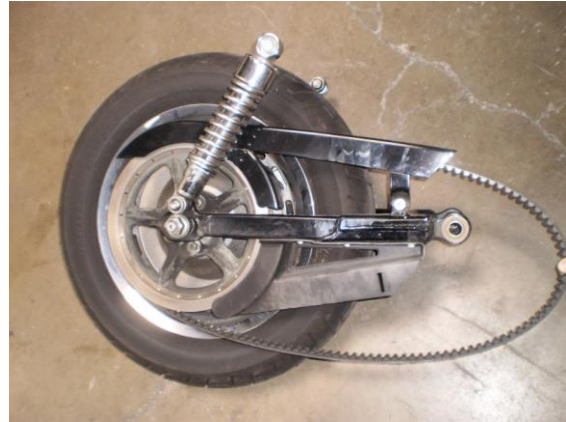

Figure 2

3. Installation of Trike Conversion Kit

3.1 Install New Supplied Belt onto Front Counter Sprocket from Box 2

- a. See OEM manual for belt installation instructions.

3.2 Install OEM Swing Arm Pivot Bearings with C-Clips into Champion Swing Arm from Box 3

- a. See OE manual for detailed bearing install instructions, noting use of HD special tools. Figure 3

CAUTION: When installing bearing, always press on outer race.

3.3 Installing Champion Swing Arm to Vehicle

- a. Coat OE pivot bolt threads with “Blue Loctite” thread lock.
- b. Install Champion swing arm on frame.
- c. Use OE pivot bolts and torque to 70 lb. ft.

3.4 Install Shocks

- a. Bolt shocks from Box 1 to OE upper shock mount and swing arm as shown using the supplied hardware from Box 2. Figure 4

Qty per side	Description
1	1/2-13x4-1/4 socket head bolt
3	1/2 SAE SS flat washer
1	Upper shock pacer
1	1/2-20x2-1/2 gr8 hex head bolt
1	1/2-20 nylock nut

3.5 Install Rear Brake Lines and Components from Box 2

- a. Attach brake line to each caliper using the supplied banjo bolts and crush washers. (Note: Use a total of three crush washers.) Figure 5
- b. Install t-block with supplied 1/4" bolt, spacer, washer, and nylock nut. Torque nut to 8 lb. ft. Figure 6

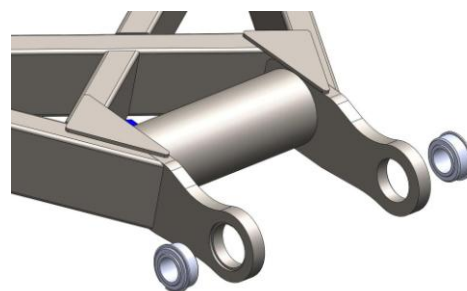

Figure 3

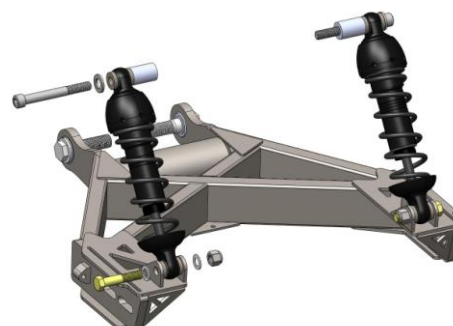

Figure 4

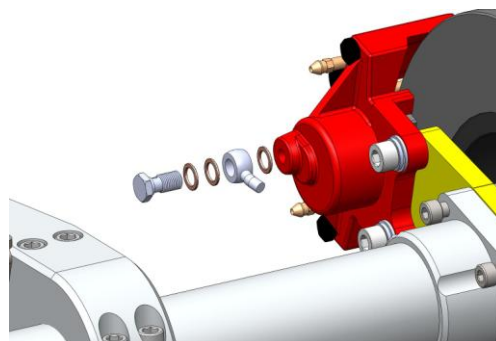

Figure 5

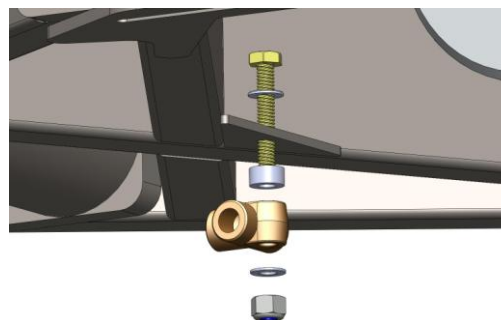

Figure 6

- c. Connect blue pressure residual valve to t-block using a crush washer between the two. Torque to 17-19 lb. ft. Figure 7

- d. Connect the supplied braided brake line to the rear master cylinder with the supplied banjo bolt with integrated pressure switch using the OE crush washers. Torque to 17-19 lb. ft. Then attach the brake line to the pressure residual valve using a 10mm single banjo bolt and two crush washers as seen in Figure 7. Torque 17 to 19 lb. ft. Use zip ties to attach the brake line to the swing arm.
- e. Crimp the supplied male spade electrical connectors to the wires on the supplied brake pressure switch. Push the male connectors into the OE female connectors and secure with zip ties.

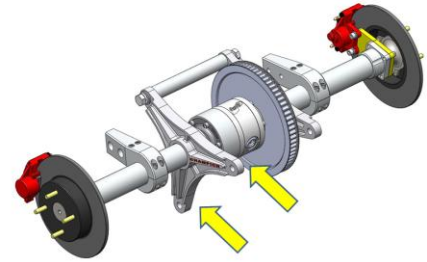

Figure 8

3.6 Assemble Rear End

- a. Slide Right Rear End Assembly (RREA) from Box 5 into Left Rear End with Differential Assembly (LREA) from Box 4.
 - Ensure RREA has grease for bearing to slide into.
 - Ensure RREA axle splines, LREA and differential are clean of debris.

*Mating of Components: Differential carrier bearing into RREA is a slip fit. If assembly binds, separate the two and ensure RREA and LREA are aligned properly. Lightly tap the two components into position with rubber mallet.

- b. Apply 2-3 drops of oil to threads of 3/4" front cross tube bolts and assemble to specified torque of 150 lb. ft. Figure 8
- c. Remove two remaining cross tubes for later installation. Figure 8

3.7 Install Rear Axle Clamps

- a. Install rear axle clamps from Box 2 using the supplied hardware. The driver side clamp slot must register into dowel pin on rear end. (Note: The rear brake lines run through each clamp with nylon protective tube.) Figure 8

Qty per side	Description
2	3/8-16x2-1/2 socket head bolt
2	3/8-16x3-1/2 socket head bolt
8	3/8 SAE SS flat washers
4	3/8-16 nylock nut

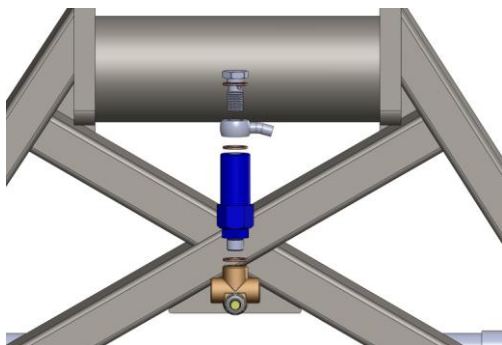

Figure 7

3.8 Install Rear End Assembly

CAUTION: Do not use air driven impact tools to assemble the Champion aluminum rear end assembly.

- a. Install the supplied 5/16-18x2-1/4 hex head adjuster bolts and jam nuts onto swing arm. Adjuster bolt should be in the furthest forward position to allow room to place belt around rear pulley in a later step. Figure 9

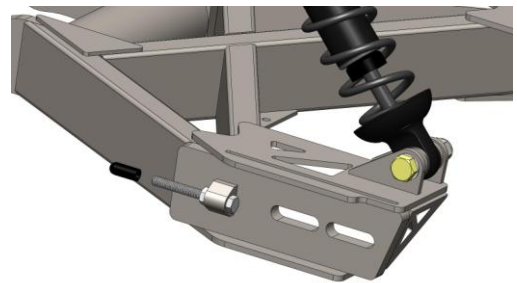

Figure 9

- b. Loosen axle housing clamps just enough to be able to align clamps with rear of swing arm.
- c. Passing the left side of the rear end assembly through drive belt, position assembly accordingly and slide axle clamps into the end of the swing arm. Figure 10

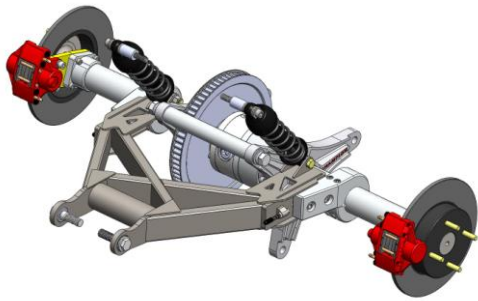

Figure 10

- d. Attach axle clamp to swing arm using the supplied hardware. Snug hardware just enough to still allow the clamp to slide against the swing arm as adjustments will be made later. Figure 11

Qty per side	Description
1	1/2-13x2-1/4 socket head bolt (front hole)
1	1/2-13x2-1/2 socket head bolt (rear hole)
4	1/2 SAE SS flat washers
2	1/2-13 nylock nut

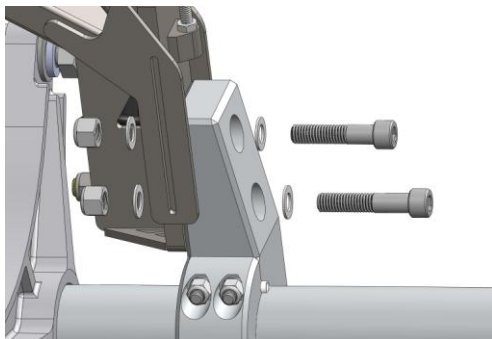

Figure 11

- e. Position drive belt onto rear pulley.
 f. Install cross tubes using 2-3 drops of oil on the cross tube bolt threads, install and torque to 150 lb. ft.

3.9 Aligning and Tensioning Drive Belt

The slots in the swing arm axle clamp mount plate allow the rear end assembly to move approximately 1.25" forward or rearward. The rear end assembly also has a total movement of approximately 1.125" side to side. This movement is accomplished by sliding the axle housing within the axle clamps; it is limited by the dowel pin and groove. The following steps are a starting point to properly align the belt.

- Center rear end assembly within the axle clamps. Ensure center by measuring from axle clamp to fender bracket on both sides until equal.
- Tighten nuts on axle clamp to 31 lb. ft. (Note: Ensure braided brake line is seated properly in saddle and does not get pinched between the two halves.)
- Adjust adjuster bolts to set belt tension and to square rear end assembly to swing arm. The belt should have approximately 3/4" of total vertical movement. Tighten jam nut to lock adjuster bolt.
- Rotate rear sprocket several times by hand to register belt on sprocket. The belt should run in the center of the rear sprocket and approximately 1/8" from inside edge of the front counter-sprocket. Make small adjustments if needed and recheck alignment. Figure 12

NOTE: Belt tension and alignment should be checked prior to final assembly of trike kit. Check with vehicle secured on jack stands and adjust accordingly if needed.

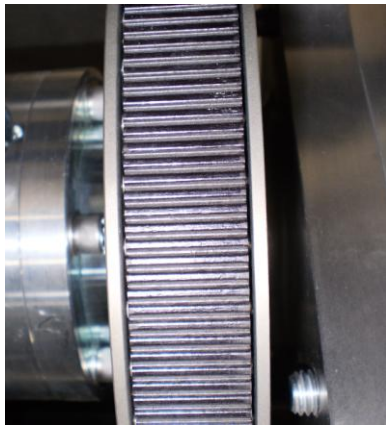

Figure 12

3.10 Connect Brake Lines to T-Block

- Connect braided lines from each wheel caliper to t-block.
- Using brake fluid specified on the master cylinder, bleed rear brake system thoroughly using the upper bleeders on rear brake calipers..

3.11 Master Cylinder Installation

- Uninstall the charcoal canister. Canister will be relocated later in instructions.
- Install master cylinder bracket to frame using two 5/16" flat washers behind bracket on LHS. Using Loctite 262, install the original Allen head bolts on LHS and original Torx head bolts on RHS. Torque to 22 ft-lbs. See Figure 13.

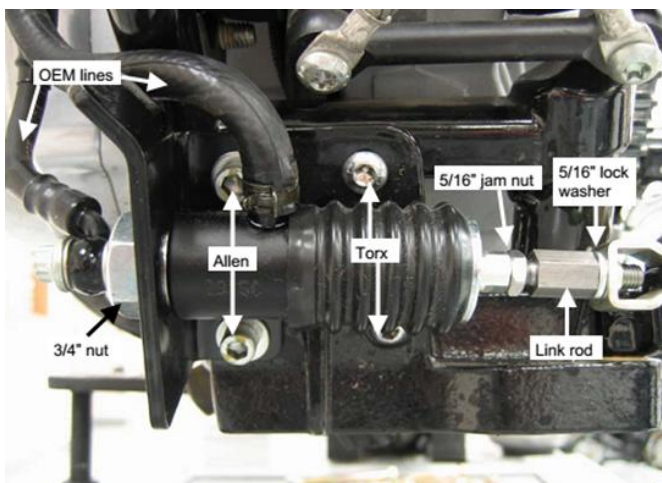

Figure 13

- Attach new master cylinder to bracket by using 3/4-16 jam nut. Use Loctite 242 and Torque to 35 ft-lbs.
- Screw long end of link rod with the 5/16-24 jam nut into the master cylinder. Place a 5/16" lock washer on short end and screw it into the HD bracket.

- Extend rod to raise pedal height to top. Lock jam nuts into place.
- Test full stroke of master cylinder and check for binding.
- Install all brake lines and clamps using new 3/8-24x3/4" banjo bolt and crush washers. Torque banjo bolt to 16 ft-lbs.
- For California trikes:** Place the charcoal canister underneath the swing arm. Use the provide two holed bracket. Use both 1/4-20x7/8" HHCS with lock washers, washers and nyloc nuts. Slide the #36 clamp between the bracket and charcoal canister. Torque to 8 ft-lbs. See both Figure 14 and Figure 15.

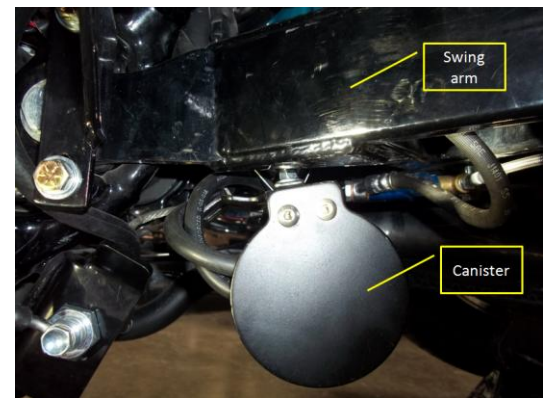

Figure 14

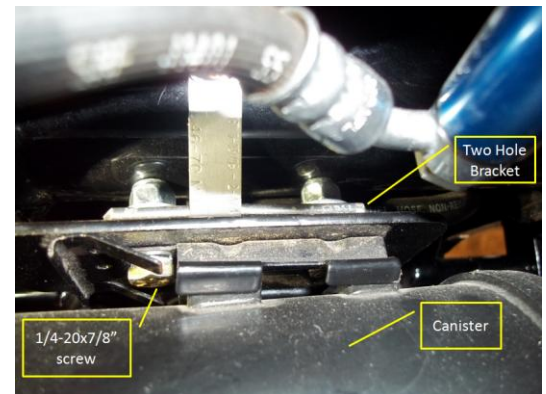

Figure 15

- Clamp around the swing arm.

3.12 Install Body

- Install rubber bumper to body support bracket using 1/2-13 x 2-1/2 screw. Place a 1/2" washer on both sides of the rubber bumper and secure with thin 1/2"

lock nut. Place a 1/2" jam nut on bolt and thread bolt onto T-bracket until the distance between top of bracket and bottom of bumper is 1-1/4". Secure jam nut to bracket as shown below.

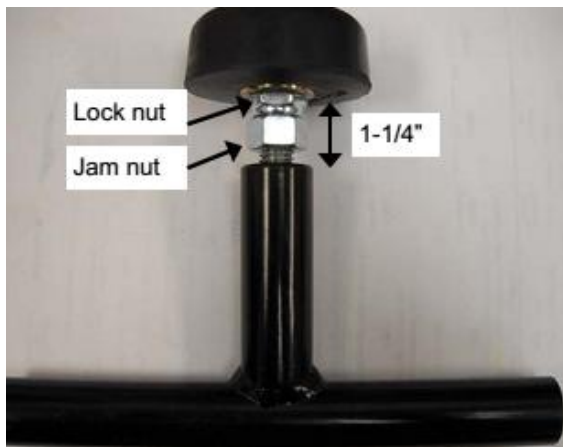

b. Install top body support to H-D frame using the hardware indicated below on both sides. See Figure 16.



Figure 16

c. Install the square support body mount onto the back of the OE bike frame. Place four 5/16 washers between the support body mount and OE bike frame. See Figure 17 which is viewing the part from bottom of trike.

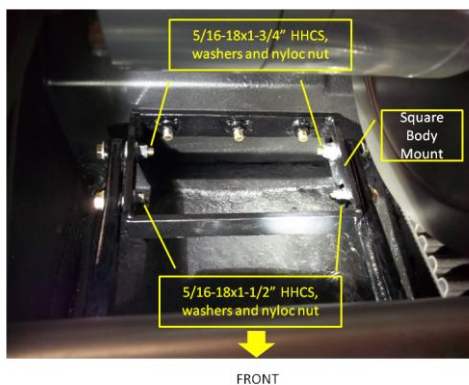
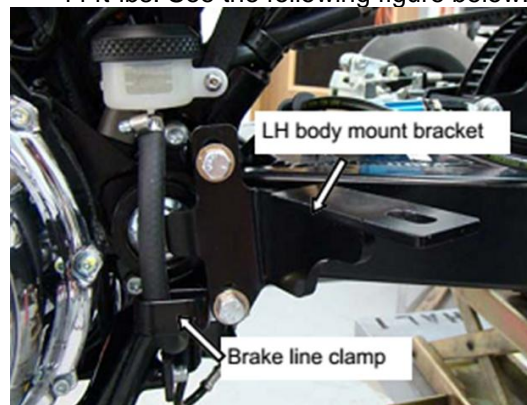

Figure 17

d. To install the LH body mount bracket, use the two short (15/16") spacers with the bracket and place it at footpeg mounting holes. Use 3/8-16x2" HHCS with lock washer and washer. Torque to 44 ft-lbs. See the following figure below.



e. For the RH body mount bracket, use both long (1-1/8") spacers with the bracket and place it at footpeg mounting holes. Use 3/8-16x2-1/4" HHCS with lock washer and washer. Torque to 44 ft-lbs.

f. To install the body remove both shocks. Place both onto both mounting brackets and rubber bumper.

g. Reinstall the shocks. Reference shock installation.

h. Slide body around the bike frame. Install the seat center post as shown below. Do not torque yet.

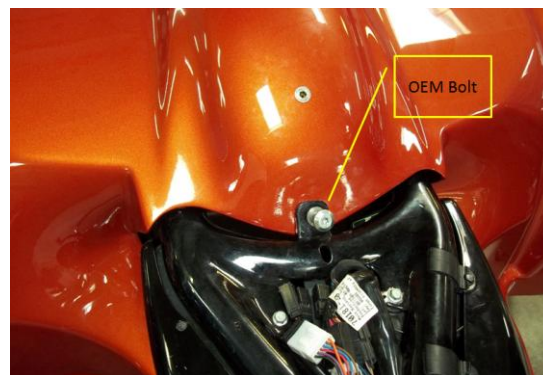

i. Verify the body has a minimum gap of 1/4" between the body and cover which is indicated in Figure 18.



Figure 18

- j. Use three 3/8-16x1-1/4 HHCS with lock washers and fender washer. See Figure 19. Torque to 26 ft-lbs.



Figure 19

- k. Peel the supplied grip tape and apply it on the body. Use both 5/16-18x1-1/4 BCHS with SS washer, washer and nyloc nut. Repeat on LHS. Torque to 20 ft-lbs. Figure 20 shows the bolt location.

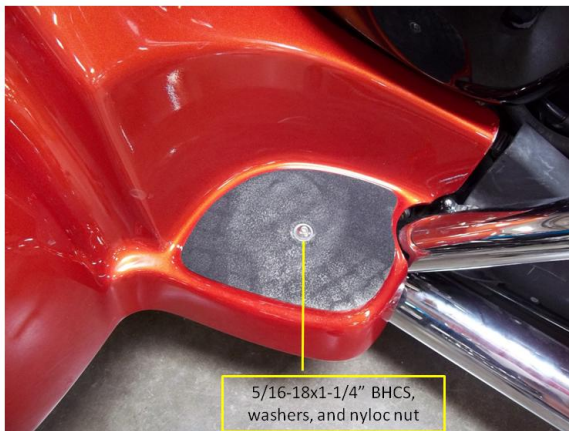

Figure 20

- l. Now torque the seat center post.
- m. Attach seat using the hardware shown below. Torque to 10 ft-lbs.



3.13 Install Wheels and Tires

- a. Install wheels with tires and torque to 75 lb. ft.
- b. Install center hub cap. Apply removable thread locking compound, Loctite™242 or equivalent, on fastener and tighten. To avoid damage to the center cap, do not overtighten.

4. Accessories

4.1 Grab Handle Installation

- a. Grab handles will be installed on body, next to the passenger section of seat.
- b. Evenly locate grab handles on body and mark for drilling. Drill holes using 1/4" drill bit.
- c. Place rubber standoff between grab handle and body.
- d. Install grab handles to body using the following hardware

Qty.	Description
4	5/16-18x1" SHCS
4	5/16" lock washers
4	5/16" washers

See Figure 21 for location.

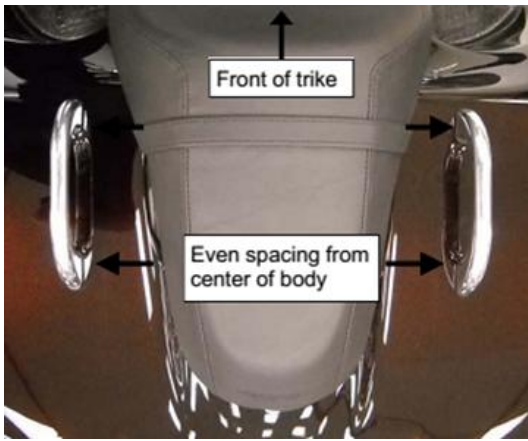

Figure 21